

Spring with Elektra

Spring pumps with electronic control for proportional dosing



SEKO has harnessed the power of data on demand and the Internet of Things (IoT) to connect its pump users to their equipment like never before with Elektra, a revolutionary controller that provides invaluable live and historical data on demand from any location worldwide.

Currently available for use with the Spring series of motor-driven pumps, Elektra uses a built-in web server to give water-treatment application managers the power to remotely monitor and adjust key pump parameters such as chemical dosage and flow rate via PC, laptop, tablet or smartphone.

This offers vast potential for precise digital dosing, process optimisation and cost control in a vast range of applications.



SEKO brings IoT to mechanical chemical dosing



Features & benefits

Digital control

- **Multiple operating modes** – timed, batch, manual, proportional from analogue or digital signals: 1:N, N:1
- **Intelligent graphic display** – shows red, yellow or green backlight, according to the current operating function
- Electronic control unit interface **can be fixed in multiple positions** to facilitate operation/installation

IoT connection

- **Remote programming and monitoring** of the pump via any internet-connected device including smartphone, tablet or PC
- **Wireless local connection to the pump** is possible even if there is no Wi-Fi at the installation site
- **Data on demand** grants secure remote data management and programming of the pump via the SekoWeb portal or app, from any location worldwide
- **Real-time and historic data available 24/7** directly to any smart device or PC, including alarms to help drive **effective maintenance planning** and rapid technical intervention



Advantages of the Spring series

- **Includes a broad range of hydraulic configurations**, reaching high flow rates up to 1,000 l/h, and backpressure up to 20 bar
- **Wide range of applications** - suitable for high-viscosity chemical applications
- **Exceptionally low operating costs** due to the outstanding ease of programming coupled with low maintenance requirement
- **Energy-efficient** motors plus a wide range of materials available for superior chemical compatibility

Spring with Elektra

Motor-driven pumps with spring return, electronic control and IoT



Smart graphic display

Offers not only a graphic intuitive interface, but also changes colour according to operating function.

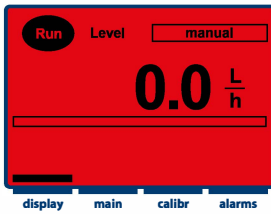

Red - shows alarm mode

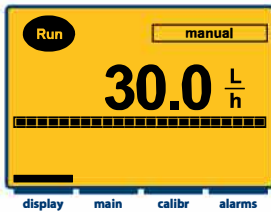

Yellow - shows the control unit is connecting to a smart device

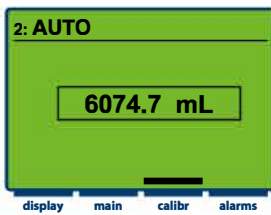

Green - shows after the successful completion of a calibration process

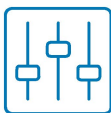

Simple fast programming

Elektra's controller allows quick and easy programming from any smart device or laptop, both remotely as well as from the display.



Manual adjustment of stroke length

Provides the ultimate in accuracy when combined with the digital dosing of Elektra's controller.



External connectors

Elektra's external connectors allow the pump to be connected to its accessories and signals from the field without opening its case. The screw terminals available in the plugs supplied allow technicians to cut the connection cables to the right length, directly in the field - enabling clean installations without the need for special tools or excess wiring.

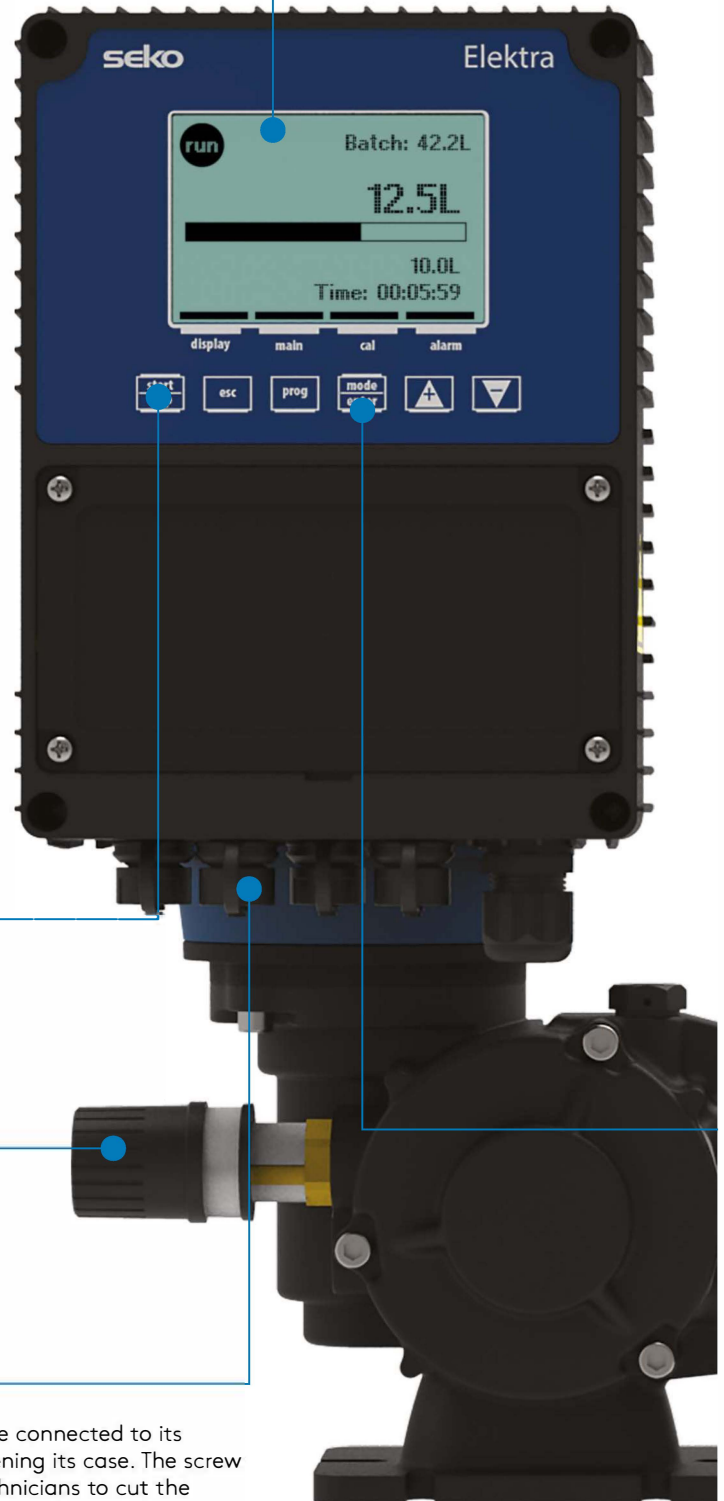

Spring with Elektra technical features

Like all Spring pumps, those equipped with Elektra are based on a spring-return mechanism housed in a sturdy aluminium case, and always provide robust, and effective power. Elektra enhances these benefits by allowing users to link the dosage to signals from the field, and monitor and to programme the pump both locally and via the internet through any smart device or PC.

Hydraulic characteristics

Model	Flow rate [l/h]	Max pressure [bar]	Frequency [stroke/1']	Stroke length [mm]	Diaphragm diameter [mm]	Ingress protection rating
MS1A/B/C Diaphragm pump	up to 500	up to 16	1 - 116	2/4/6	up to 165	IP55
PS1 D Piston pump	up to 304	up to 20	1 - 116	15	up to 64	IP55
PS2 E Piston pump	up to 1,000	up to 20	1 - 116	25	up to 89	IP55

Spring with Elektra key code

Motor type	kW [3ph]	Size
AE	0.18	63-B14
BE	0.25	71-B14
CE	0.37	71-B14
DE	0.55	80-B14
EE	0.75	80-B14
TE	0.25	71-B5
UE	0.37	71-B5

Optional
N Elektra - Wi-Fi connection

M S1 A 094 A 51 CE 0 0 N

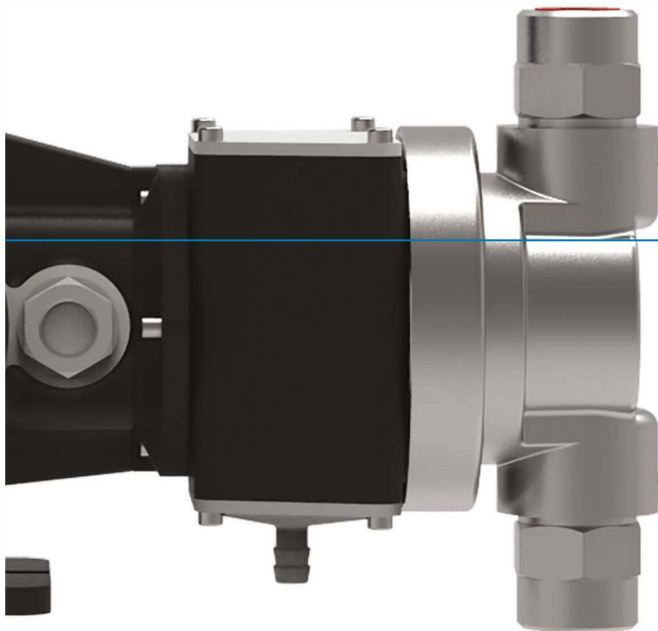

Multiple operating modes

- Manual
- Batch
- Timed
- Proportional to mA
- Proportional to V
- PPM
- Proportional to pulses